

Mounting systems for solar technology

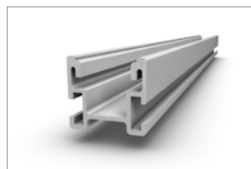
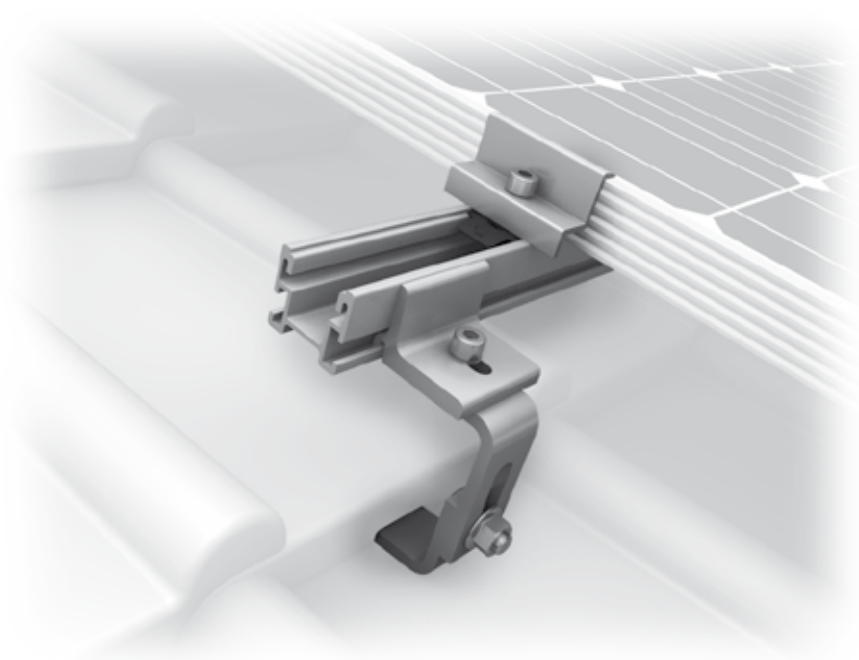

K2 SYSTEMS
SLOPED ROOF SYSTEMS
ROOF FASTENER SYSTEM CROSSRAIL

ROOF FASTENER SYSTEM CROSSRAIL

- K2 Systems roof fastener system developed for flat tiles
- Easy installation with screw connection from above with optimum accessibility with the K2 CrossRail and K2 Climber
- Excellent corrosion resistance thanks to use of high-quality aluminium alloys and stainless steel components
- High level of flexibility due to adjustability of height under bracket (depending on type),
- Static proven solution using the K2 Base Planning Software
- Round slot image for full-compliant mounting on narrow sub-structures and on wooden substructures
- Suitable for narrow width rafters
- Sophisticated geometry and targeted use of materials allows for increased spans
- Very easy to assemble with simple system components
- Modular design allows any size of system

Technical data



Field of application	Sloped roof
Roofing	Pan tiled roofs
PV modules	Suitable for all standard module types
Module orientation	portrait / landscape (with cross bracing)
Material	Aluminium (EN AW-6063 T66), stainless steel 1.4301
Connecting elements	Stainless steel A2-70
Roof connection	Screw connection
Rafter width	From 36 mm
Static principles	Determination of load capacity values by independent test institutes, screw connection in accordance with Eurocode 5
Load assumption in accordance with	DIN EN 1991 (Eurocode 1)
System components	Roof fastener CrossHook range, K2 CrossHook 3S, K2 Climber, K2 CrossRail range, end and mid clamp set, rail connector, Allen bolts, M K2



Detail illustration - adjustable height settings CrossHook 3S
Adjustable height settings (40/47/54mm)



Explosion drawing - Montage CrossRail

SERVICE-HOTLINE
+49 (0)7152 3560-0
www.k2-systems.com

Produktblatt DH CR | GB3 | 0513 | Subject to change
Product illustrations are exemplary illustrations and may differ from the original.

